



SEWOO TECH CO., LTD.

374-2, Gajang-dong, Osan-si, Gyeonggi-do, 447-210, Korea
TEL : +82-31-459-8200 FAX : +82-31-459-8880
www.miniprinter.com



MODEL : LK-P43B (Peeler)

USER'S MANUAL



“Made for iPod,” “Made for iPhone,” and “Made for iPad” mean that an electronic accessory has been designed to connect specifically to iPod, iPhone, or iPad, respectively, and has been certified by the developer to meet Apple performance standards. Apple is not responsible for the operation of this device or its compliance with safety and regulatory standards. Please note that the use of this accessory with iPod, iPhone or iPad may affect wireless performance.



**RISK OF EXPLOSION IF BATTERY IS REPLACED BY AN INCORRECT TYPE.
DISPOSE OF USED BATTERIES ACCORDING TO THE INSTRUCTION**



Disposal of Old Electrical&Electronic Equipment(Applicable in the European Union and other European countries with separate collection systems)

This symbol on the product or on its packaging indicates that this product shall not be treated as household waste.

Instead it shall be handed over to the applicable collection point for the recycling of electrical and electronics equipment. For more detailed information about recycling of this product, please contact your local city office, your household waste disposal service or the shop where you purchased the product.

Table of Contents

1. Safety Caution	4
2. Unpacking	6
3. Product Overview	7
4. Installation & Usage	8
4-1. Display	8
4-2. Installing the Battery	9
4-3. Removing the Battery	10
4-4. Charging the Battery	11
4-5. Battery charger usage	12
4-6. Usage of Cigar Jack Charger	13
4-7. Installing Belt Clip	14
4-8. Interface Cap Installation	15
4-9. Roll Paper Installation	16
4-10. Install / Uninstall the External Paper Guides	18
4-11. Peel Mode	20
4-12. Shoulder Strap Installation	22
4-13. Diagnostic Test	23
5. Peripherals Connection	25
5-1. Bluetooth Connection	25
5-2. Interface Cable Connection	26
6. Printer Cleaning	27
6-1. Print-Head Cleaning	27
6-2. Platen Roller Cleaning	28

7. Pritner Specification	29
7-1. Specification	29
8. CPCL Command Compatibility	31
9. ESC/POS Command Compatibility	34
10. ZPL Command Compatibility	36

1. Safety Caution

For higher reliability and safety, consider the following precautionary measures. Read and follow the instructions carefully before running of the product.

Indication



Prohibition



Must follow



Do not disassemble



Unplug the power from the outlet



Grounding to prevent electric shock



Do not handle the product with wet hands



WARNING

Failure to follow these instructions could result in fire, electric shock, or other injuries, or property damage

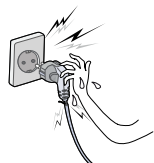

Do not pull or touch the power plug with wet hands.

(Potential risk of electric shock or fire)

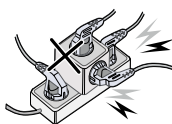

Do not overload the power plug into one outlet.

(Potential risk of electric shock or fire)



Do not bend the wire and do not allow the wire to be pressed by heavy object.

(Potential risk of electric shock or fire)

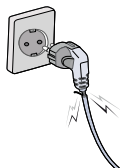

If a power plug is broken or a plug is cut or worn, do not use it.

(Potential risk of electric shock or fire)



WARNING

Failure to follow these instructions could result in fire, electric shock, or other injuries, or property damage

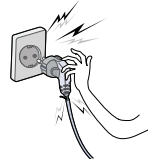

Do not pull out the power plug to turn off the product.

(Turn off the power at installation, transportation, wiring and inspection.)

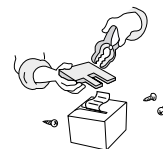

Do not disassemble, repair or modify the product.

(Potential risk unit malfunction, electric shock or fire. When the product needs to be repaired, please contact in place where you ordered.inspection.)



CAUTION

Failure to follow these instructions could result in fire, electric shock, or other injuries, or property damage



Do not install the product in uneven or inclined surface.

(You may get hurt and it can be broken when it falls)



Keep product away from the water and other material.

(Potential risk of discoloration or electric shock)

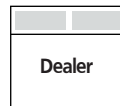

If the product that needs to be repaired, please contact in place where you ordered.

(Potential risk of fire or unit malfunction)

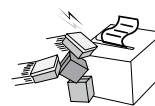

Please do not give excessive shock.

(Potential risk of fire or unit malfunction)

2. Unpacking

Standard



Printer

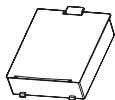

Battery



Belt Clip

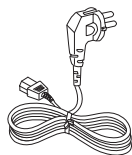

AC cord

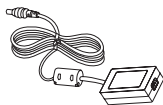

Adaptor

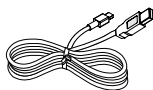

USB Cable

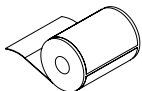

Paper

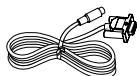

Serial Cable



CD



Quick Reference

Optional

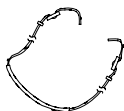

Shoulder Strap



Cigar Jack

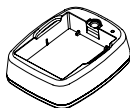

Battery Cradle

3. Product Overview

Front

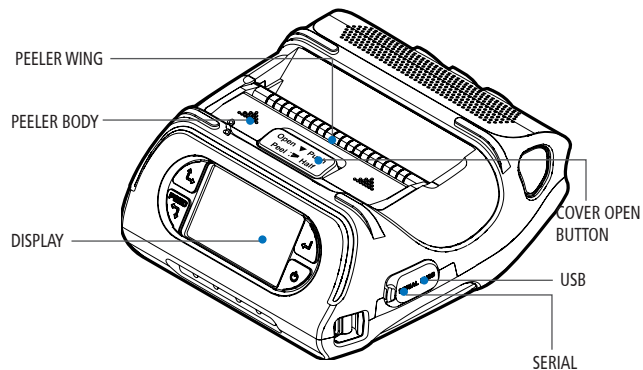



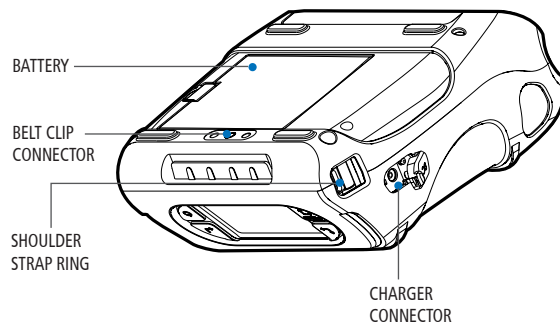

Bottom

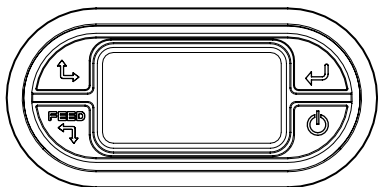

4. Setting Up the Product

4-1. Display



Button	Name	Function
	Paper Feed / Down Button	Advances the supply. Clears error message. Moves down through menu options. 1. Refer to 4-9 for Diagnostic Test information. 2. Refer to the service manual regarding Hexadecimal Dumping.
	Enter Button	Selects the highlighted menu option.
	Up Button	Moves up through menu options.
	Power Button	Turns the printer on and off. Press to turn power on. Press for three seconds to turn power off. Wakes the printer from sleep mode.

NOTE

1. The battery status LEDs indicate amount of power remaining. Actual run-time remaining depends on factors such as the contents of output, distance to computer, etc.
2. When the battery level is very low, high density printing can result in the printer switching off during printing resulting in possible loss of data.

4-2. Installing the Battery

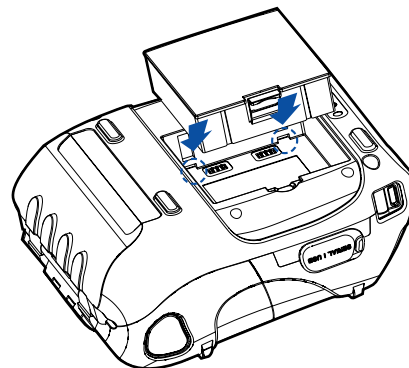

Remove the battery. Insert the battery as shown.
Replace the battery.

NOTE

You must fully charge the battery when you receive the printer.
Batteries can be charged in the printer or in an optional external cradle.

4-3. Removing the Battery

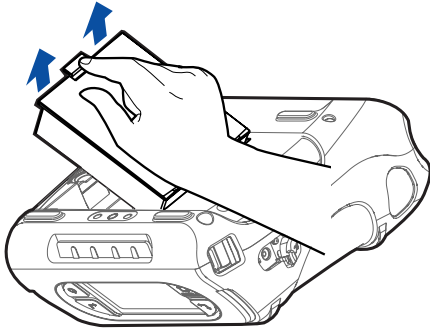

Remove the battery. Lift out the battery.

4-4. Charging the Battery

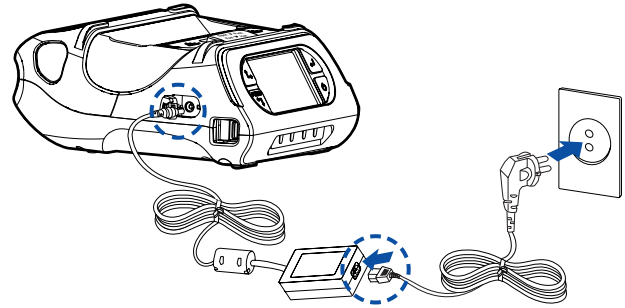

1. Be sure that the printer is turned off
2. After open the DC JACK cover, insert DC JACK into the printer.
3. Plug the power code to electrical outlet.

4-4-1 The status of lamp in charging

Status	Charging	Charging Completed
Charging Lamp	Red	Green

NOTE

If there is trouble while charging the battery, the charge indicator LED blinks green. Try unplugging and reconnecting charger, charging should resume. Charging is complete when the LED changes to solid green.

4-5 Battery charger usage

Optional

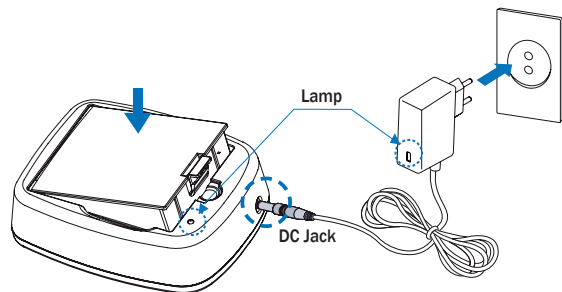

1. Insert the battery into the battery holder as shown above
2. Connect the DC JACK to the power electrical outlet.
3. Plug the power code into the electrical outlet.
4. Once the charging is completed, remove the battery from the holder.

4-5-1 The status of lamp in charging

Status	charging	charging complete
Charging Lamp	Red	Green

NOTE

In the case the battery is not fixed properly in the holder, the red lamp will be blinking. Then, extract and reinsert the battery.

4-6. Usage of Cigar Jack Charger

Optional

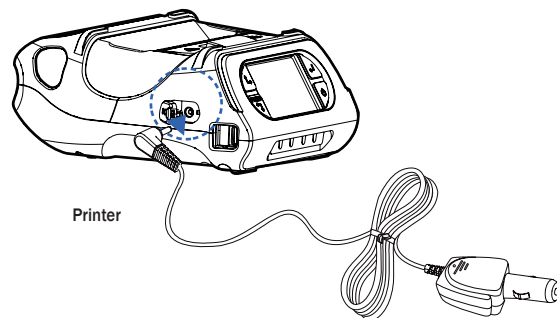

Connect the vehicle charger to the printer.

Input	12V ~ 24V
Output	9.5V / 3A

NOTE

Connect the vehicle charger to the printer.

4-7. Belt Clip Usage

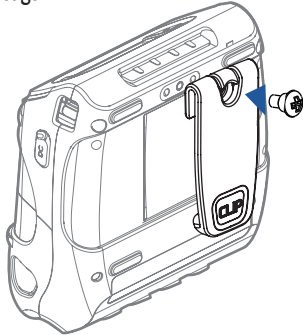

Insert screw into belt clip.

1
2

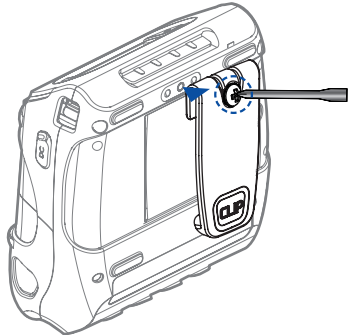

Tighten the screw with driver as shown.

NOTE

The belt clip is included with the printer but is not required to be used or installed!

4-8. Interface Cap Installation

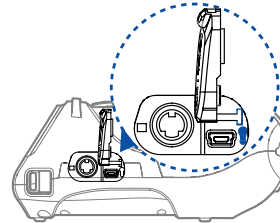

When Interface Cap separated from the printer, try to array the Cap Hook in horizontal direction as shown in the image.

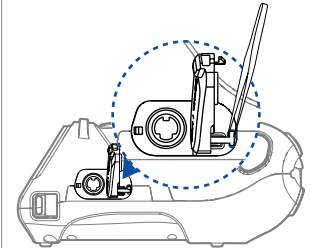

Using a sharp tool, insert the Cap Hook to the hole which is located in the right side of Interface Cap.

1 2
3 4

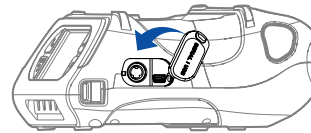

When Cap Hook inserted, install the Cap Cover in direction of an arrow as shown in the image.

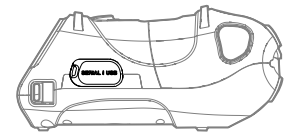

Close the Interface Cap cover.

4-9. Roll Paper Installation

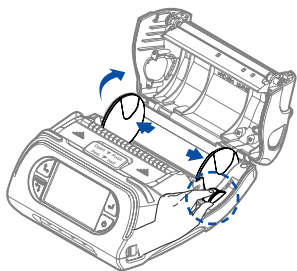

Open the Paper cover by pressing the Open button and set the width of paper guide by turning the knob with finger.

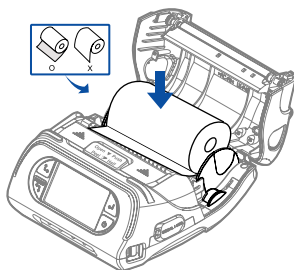

Put the stock in so it unrolls from the bottom. Remove the stock core when it is empty. Pull a short length of stock out of the printer.

1 2
3 4

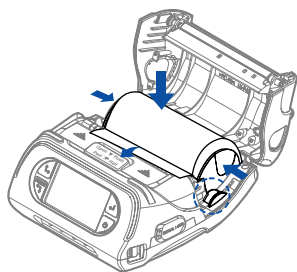

After inserting the paper, adjust the paper guide to little wider than paper size. Then pull the paper out and close the paper cover.

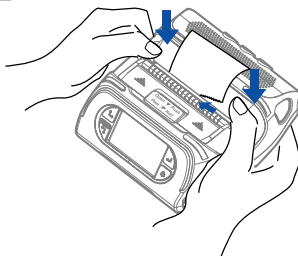

Close the Paper cover with both hands and run the paper line up by pressing the Feed button.

NOTE

If the users close the cover with one hand, it would not be closed completely. Please use both hands to close.



Be cautious to handle the product when Printer Cover is an open position. You may have a potential risk of injury when Paper Cover closes

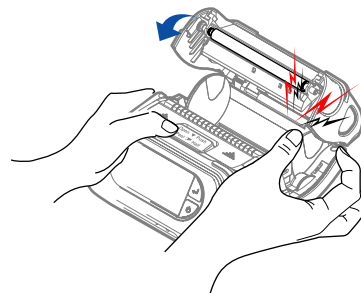

4-10. Install / Uninstall the External Paper Guides

Uninstall the External Paper Guides

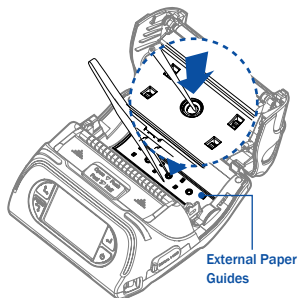

Using sharp tool, push External Paper Guides in order to detach from the printer. Press circle on the middle of external paper guide with tool.

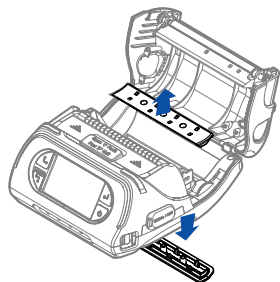

The outer cover of External Paper Guides will be separated.

1 2
1 2

Install the External Paper Guides

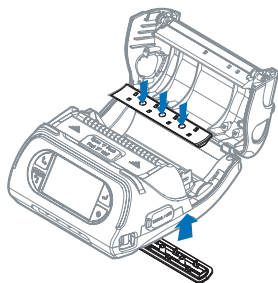

Assemble two (inner & outer) External Paper Guides as shown in figure and press three points to fix firmly inner guide with outer guide.

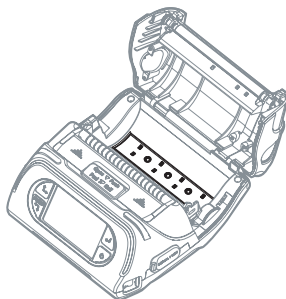

Two external paper guides will be installed to printer.



When install the external paper, set the printer 20mm above from the ground. Then insert the paper in right direction to the backside of the printer paper slot and adjust the paper guide to fit the paper properly.

Recommendation

Please set apart the printer and paper at least twice of the paper length.

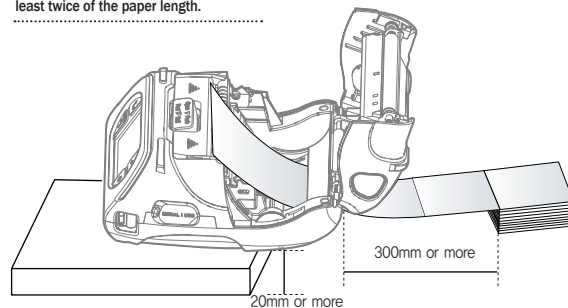

4-11. Peel Mode

Peel Mode

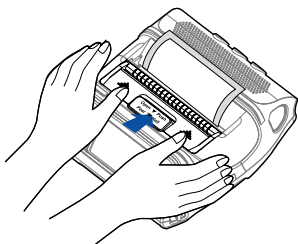

With a roll of stock installed, slide the peeler body towards the back of the printer.

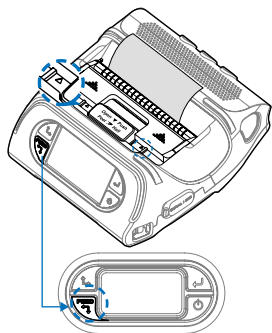

Push the peeler body until you see two complete triangles. Press the Feed button.

1 2
1 2

Non-Peel Mode

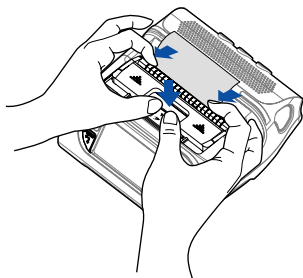

Pull down the Peeler Wing while pressing the Cover open button slightly.

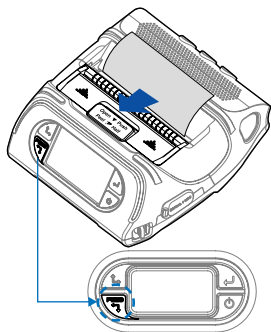

Press the Feed button.



When users operates the peeler like the image below that has slits on the label(1) and the perforated label(2), there might be an error in the peeler function

Paper (1)

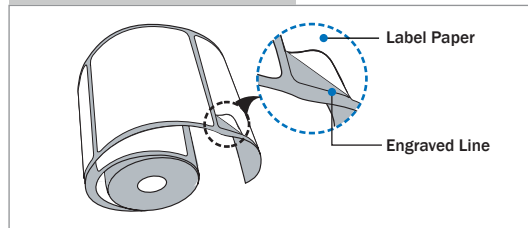

Paper (2)

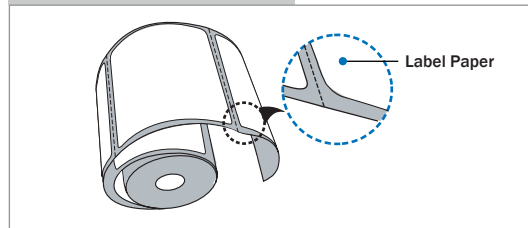

4-12. Shoulder Strap Installation

Optional

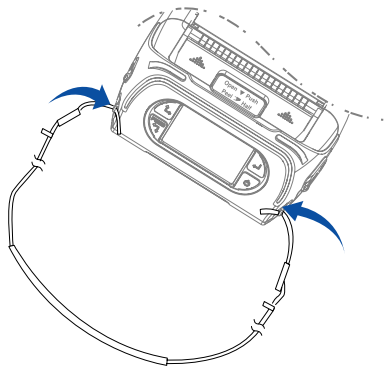

Insert the strap into the hook of the printer.

1
2 3

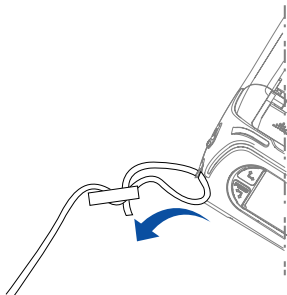

Place the end of the strap into the hook of shoulder strap.

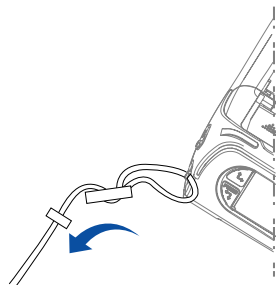

After pulling out the end of the strap tightly, put it into the clip to be fastened.

4-13. Diagnostic Test

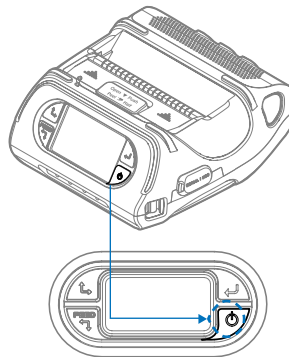

Turn off the printer.

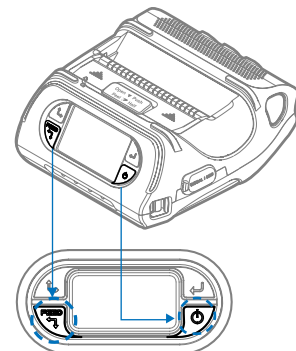

Press and hold the Feed button and Power button.

1
2
3

NOTE

1. For Hex Dump mode, do steps 1-2 then press the Feed button.
2. After printing ASCII pattern, the diagnostic test is complete.
3. If the Feed button is not pressed to go to Hex Dump mode, the printer exits diagnostics after three seconds.



The information label prints.

The Sample of Self-test Printout

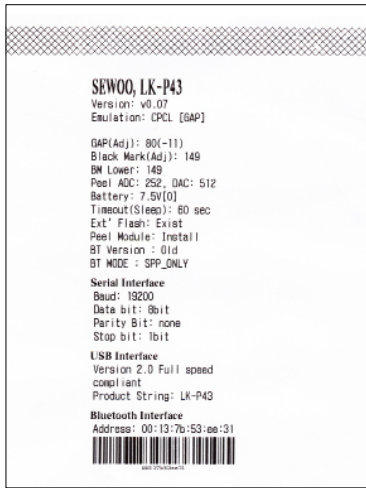

Upon initial installation or for troubleshooting, you can run the diagnostic test to get information about:

Firmware version, emulation, codepage, sensor settings, interface settings, etc. If no issues are found with diagnostic test, examine other devices and software. The diagnostic test is working independent of devices and software.

● Do Not Overheat the Motor

To prevent the motor from overheating, stop the printer for at least 30 seconds after continuously printing 1.5 meters.

5. Peripherals Connection

This printer can communicate with peripherals device via Bluetooth and Cables.

5-1 Bluetooth Connection

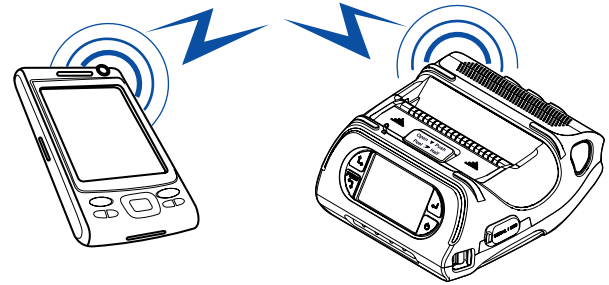

1. Printer can be connected to the PDA and PC which can do wireless communication.
2. By using Bluetooth function supported in PC, printer can be connected.

✔ NOTE

Refer to the System Administrator Guide for more information.

5-2. Interface Cable Connection

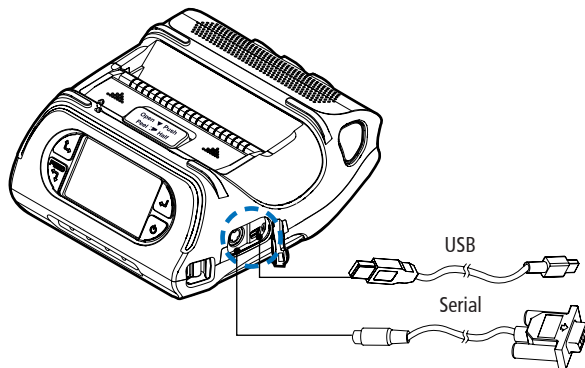

1. Connect the USB or Serial cable to the cable connector on the printer.

✔ NOTE

Use cable only offered by the printer manufacturer.

2. Connect the interface cable into the USB or Serial port of the device (PDA, PC, etc.)

6. Printer Cleaning

If the interior of the printer is dusty, printing quality can be lowered. In this case, follow the instructions below to clean the printer.

6-1. Print-Head Cleaning

1. Use an applicator swab moistened with an isopropyl alcohol to clean the print-head and remove any dust.
2. Once cleaning is complete, allow the printer to dry then install the stock and close the cover.

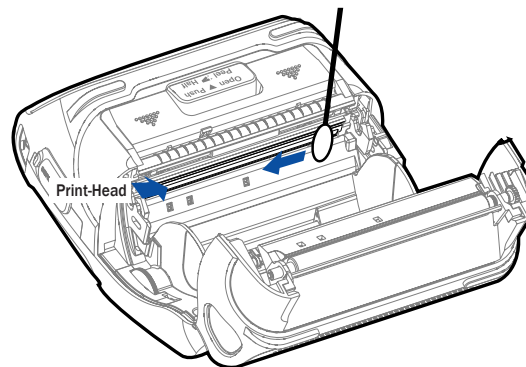

✔ NOTE

1. Make sure to turn the printer power off prior to cleaning.
2. The print-head can become very hot during printing; allow the printer approximately 10 minutes to cool before cleaning.
3. Do not touch the print-head, it can be damaged by static electricity.
4. Take care not to allow the print head to become scratched and / or damaged in any way.

6-2. Platen Roller Cleaning

1. Clean the platen roller with a clean soft cloth moistened with isopropyl alcohol or a cleaning pen.
2. Turn the platen roller with your finger to clean the

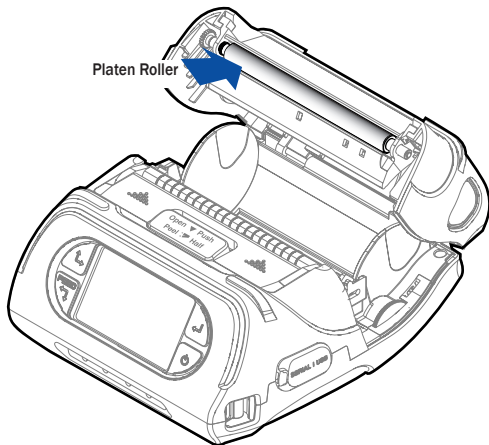

7. Printer Specification

7-1. Specification

Printing Method		Direct Thermal
Printing Speed		80mm/sec
Resolution		203 DPI X 203 DPI
Character		ALPHA NUMERIC Character, Extension Character
Barcode	One-Dimensional Barcodes	UPCA +2/+5, UPCE +2/+5, EAN8 +2/+5, EAN13 +2/+5, EAN 128, Interleaved 2 of 5, Extended Code 39, Codabar (NW7), Code 128, Code 93, PostNet
	Two-Dimensional Barcodes	PDF417, MaxiCode, Aztec, QR Code (Quick Response), Datamatrix
	Stacked One-Dimensional Barcodes	GS1 Databar (RSS or Composite Code)
Emulation		ESC/POS, ZPL, CPCL Command compatible
Driver		Windows (2000, XP, Vista, 7, 8), Symbian OS, Windows mobile (Pocket PC, 2003, 6x), Android, Windows CE 4.2/5.0/6.0, Linux, Blackberry
Sensor		Black-Mark Upper/Lower, Gap, Cover open, Peeler Detect, Peeler S/W, Media-Width Detect
Paper	Paper Type	Thermal Paper
	Width	50~112mm
	Thickness	Roll : 0.06 ~ 0.165 mm / Fanfold : 0.06~0.15 mm
	External Diameter	Max. ϕ 58mm
	Internal Diameter	12.5mm \pm 0.5mm
Reliability	TPH	50km
	Battery	Continuous Printing 62min Standby for 60hours Printing Length: 140M
MEMORY		Up to Flash 32MB
Communications	standard	Serial(RS-232C), USB
	Optional	Bluetooth Class2

8. CPCL Command Compatibility

Display		TFT-LCD (RGB) 240X400
Adaptor	Input	AC 100 ~240V 50/60Hz
	Output	9.0V, 4.0A
Battery	Battery Type	Li-ion
	Output	STANDARD : 7.4V, 2600 mAh/19.24Wh OPTION : 7.4V, 5200 mAh/38.48Wh
	Charging Time	3.3 Hrs Charging
Size	WXDXH(mm)	166X 174 X 80
	WXDXH"	6.5 X 6.8 X 3.1
Weight		1Kg (With battery)
Environment Sealing		IP54
Temperature	Operation	-21 ~ 55°C
	Storage	-30 ~ 65°C
Humidity	Operation	10 ~ 90%
	Storage	10 ~ 90%

NOTE

Compatible	Compatible with only commanders provided by the manufacturer.	Partially Compatible	Not Compatible
○	●	△	x

Printer Commands	Compatibility
PRINT	○
FORM	○
JOURNAL	○
UNITS	○
USING COMMENTS	○
TEXT	Compatibility
TEXT	○
FONT-GROUP(FG)	○
TEXT CONCATENATION	○
MULTILINE(ML)	○
COUNT	○
SETMAG	○
SCALABLE TEXT	Compatibility
SCALE-TEXT	○
SCALABLE CONCATENATION	○
LINEAR BARCODES	Compatibility
BARCODE	○
BARCODE-TEXT	○
COUNT	○
Two-Dimensional Bar Codes	Compatibility
PDF417 (PORTABLE DATA FILE)	○
MICROPDF-417	●
MAXICODE	○
QR CODE	○

DATAMATRIX	●
GSI (RSS-14)	○
AZTEC	○
GRAPHICS	Compatibility
BOX	○
LINE	○
INVERSE-LINE	○
PATTERN	○
GRAPHICS	○
PCX	○
Advanced Commands	Compatibility
CONTRAST	○
TONE	○
JUSTIFICATION	○
PAGE-WIDTH	○
PACE	○
NO-PACE	○
WAIT	○
SPEED	○
SETSP	○
ON-FEED	○
PREFEED	○
POSTFEED	○
COUNTRY/CODE PAGE	○
FORMAT FILES	○
BEEP	○
Line Print Mode	Compatibility
SETLP	○
SETLF	○
Moving With X and Y Coordinates	○
LMARGIN	○

SETBOLD	○
SETSP	○
Special ASCII Characters	○
SETFF	○
SET-TOF	○
SETLP-TIMEOUT	○
ADVANCED UTILITIES	Compatibility
VERSION	○
CHECKSUM	○
DEL	○
DIR	○
DEFINE-FILE	○
TYPE	○
BAUD	○
COUNTRY / CODE-PAGE	○
TIMEOUT	○
BEED	○
ON-LOW-BATTERY	○
LT	○
SET-TIME	○
GET-TIME	○
SET-DATE	○
GET-DATE	○
PRINTING A TIME STAMP	○
PRINTING A DATE STAMP	○
PAPER-JAM	○
PRINTER ESCAPE	Compatibility
SET AND READ CODE	△
STATUS / INFORMATION	○
USER LABEL COUNT	○
POWER OFF	○

9. ESC / POS Command Compatibility

Command	Function	Compatibility
HT	Horizontal tab	○
LF	Print and line feed	○
CR	Print and carriage return	○
FF	Print end position label to start printing	○
CAN	Cancel print data in page mode	○
DLE EOT	Real-time status transmission	○
DLE ENQ	Real-time request to printer	○
ESC FF	Print data in page mode	○
ESC SP	Set character right-side spacing	○
ESC !	Set print mode	○
ESC \$	Set absolute print position	○
ESC %	Select/cancel user-defined character set	○
ESC &	Define user-defined characters	○
ESC *	Set bit image mode	○
ESC -	Turn underline mode on/off	○
ESC 2	Set 1/6 inch line spacing	○
ESC 3	Set line spacing using minimum units	○
ESC ?	Cancel user-defined characters	○
ESC @	Initialize printer	○
ESC D	Set horizontal tab positions	○
ESC E	Select emphasized mode	○
ESC G	Select double-strike mode	○
ESC J	Print end feed paper using minimum units	○
ESC L	Select page mode	○
ESC M	Select character font	○
ESC R	Select international character set	○
ESC S	Select standard mode	○
ESC T	Select print direction in page mode	○
ESC V	Set/cancel 90° rotated character	○
ESC W	Set printing area in page mode	○

Command	Function	Compatibility
ESC \	Set relative position	○
ESC a	Align position	○
ESC d	Print and feed paper n lines	○
ESC t	Select character code table	○
ESC {	Set/cancel upside-down character printing	○
FS p	Print NV bit image	○
FS q	Define NV bit image	○
GS !	Select character size	○
GS \$	Set absolute vertical print position in page mode	○
GS *	Define downloaded bit image	○
GS /	Print down-loaded bit image	○
GS B	Turn white/black reverse printing mode on/off	○
GS H	Select printing position of HRI characters	○
GS I	Transmit printer ID	○
GS L	Set left margin	○
GS W	Set printing area width	○
GS \	Set relative vertical print position in page mode	○
GS a	Enable/disable Automatic Status Back(ASB)	○
GS f	Select font for HRI characters	○
GS h	Set bar code height	○
GS k	Print bar code	○
GS r	Transmit status	○
GS v 0	Print raster bit image	○
GS w	Set bar code width	○
GS S C	Set Serial Baudrate	○
DLE EOT n	Selects card read mode / Cancel card read mode	○
GS S P	Power Save Mode	○

10. ZPL Command Compatibility

Command	Compatibility
^A	○
^B0	○
^B1	○
^B2	○
^B3	○
^B4	○
^B5	○
^B6	○
^B7	○
^B8	○
^B9	○
^BA	○
^BB	○
^BC	○
^BD	○
^BE	○
^BF	○
^BI	○
^BJ	○
^BK	○
^BL	○
^BM	○
^BO	○
^BP	○
^BQ	○
^BR	○
^BS	○
^BT	○
^BU	○

Command	Compatibility
^BX	○
^BY	○
^BZ	○
^CC ~CC	○
^CD	○
^CF	○
^CI	○
^CT ~CT	○
~DF	○
~DG	○
^FB	○
^FC	○
^FD	○
^FH	○
^FN	○
^FO	○
^FP	○
^FR	○
^FS	○
^FT	○
^FV	○
^FW	○
^FX	○
^GB	○
^GC	○
^GD	○
^GE	○
^GF	○
^GS	○

Command	Compatibility
^ID	○
^IL	○
^IM	○
^IS	○
~JR	○
^JS	○
~JS	○
^KL	○
^LH	○
^LL	○
^LR	○
^LS	○
^LT	○
^MC	○
^MD	○
^MN	○
^PM	○
^PO	○
^PQ	○
^PR	○
~PR	○
^PW	○
^SC	○
^SD	○
^SF	○
^SL	○
^SN	○
^SO	○
^ST	○

Command	Compatibility
~TA	○
^XA	○
^XF	○
^XG	○
^XZ	○
^ZZ	○

